



**TRIOBIKE**



# Hafnia



## build up

FRAME: steel, powder coated

BOX: plywood

REAR WHEEL: 26"

FRONT WHEELS: 20"

## e-system

MOTOR: Bafang H610 rear drive, 65 Nm

DISPLAY: display & remote control included

BATTERY: Li-Ion cells, 468 Wh

E-SYSTEM WARRANTY: 1 - 2 years

## components

BRAKES: Bengal hydraulic disc brakes with parking lock

GEARS / TRANSMISSION:  
external 7 gears (14t - 28t) / chain

LIGHTS: integrated front and rear lights

TIRES: Kenda 2.4", puncture free + reflex

FRAME LOCK: compatible with AXA Imenso Large, ABUS 4750XL, ABUS 4650XL and similar sized (not included)

SEAT POST: length 450 mm

STEERING DAMPER: two included

SADDLE: triobike gel

## dimensions

BIKE:

LENGTH: 221 cm  
WIDTH: 91 cm

BOX:

WIDTH: 68 cm, inside 66 cm  
LENGTH: 101 cm outside, 99 cm

WEIGHT: 68 kg

MAX PAYLOAD ON THE FRONT BOX: 100 kg

MAX TOTAL WEIGHT: 250 kg

MAX OVERALL LOAD (RIDER+PASSENGERS): 182 kg

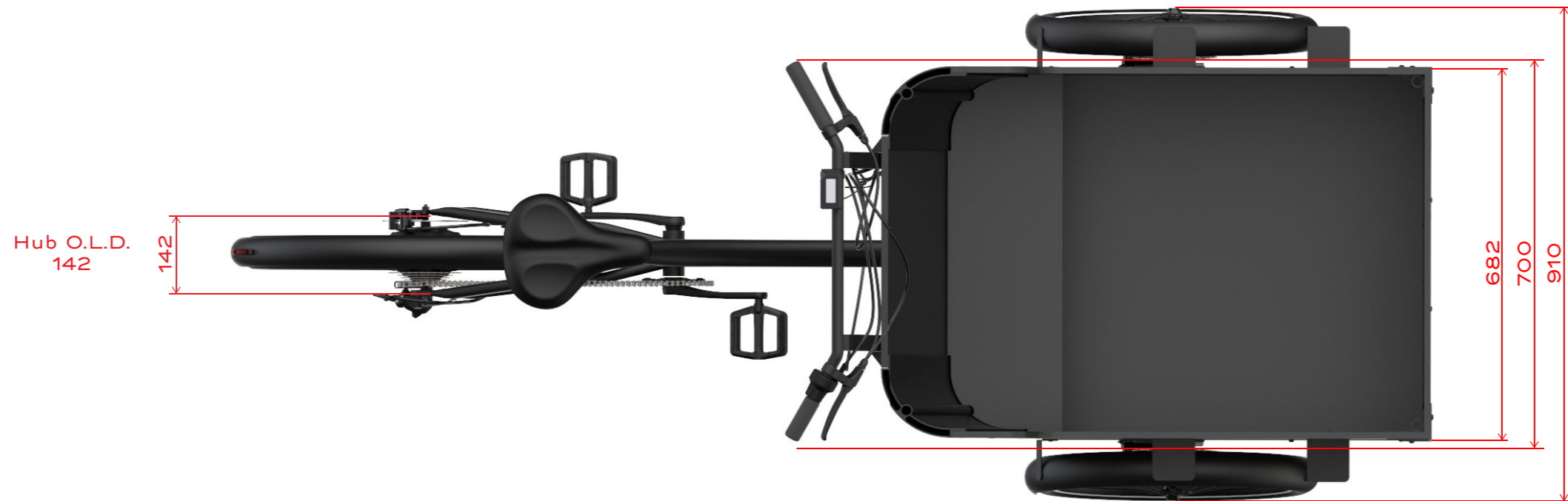
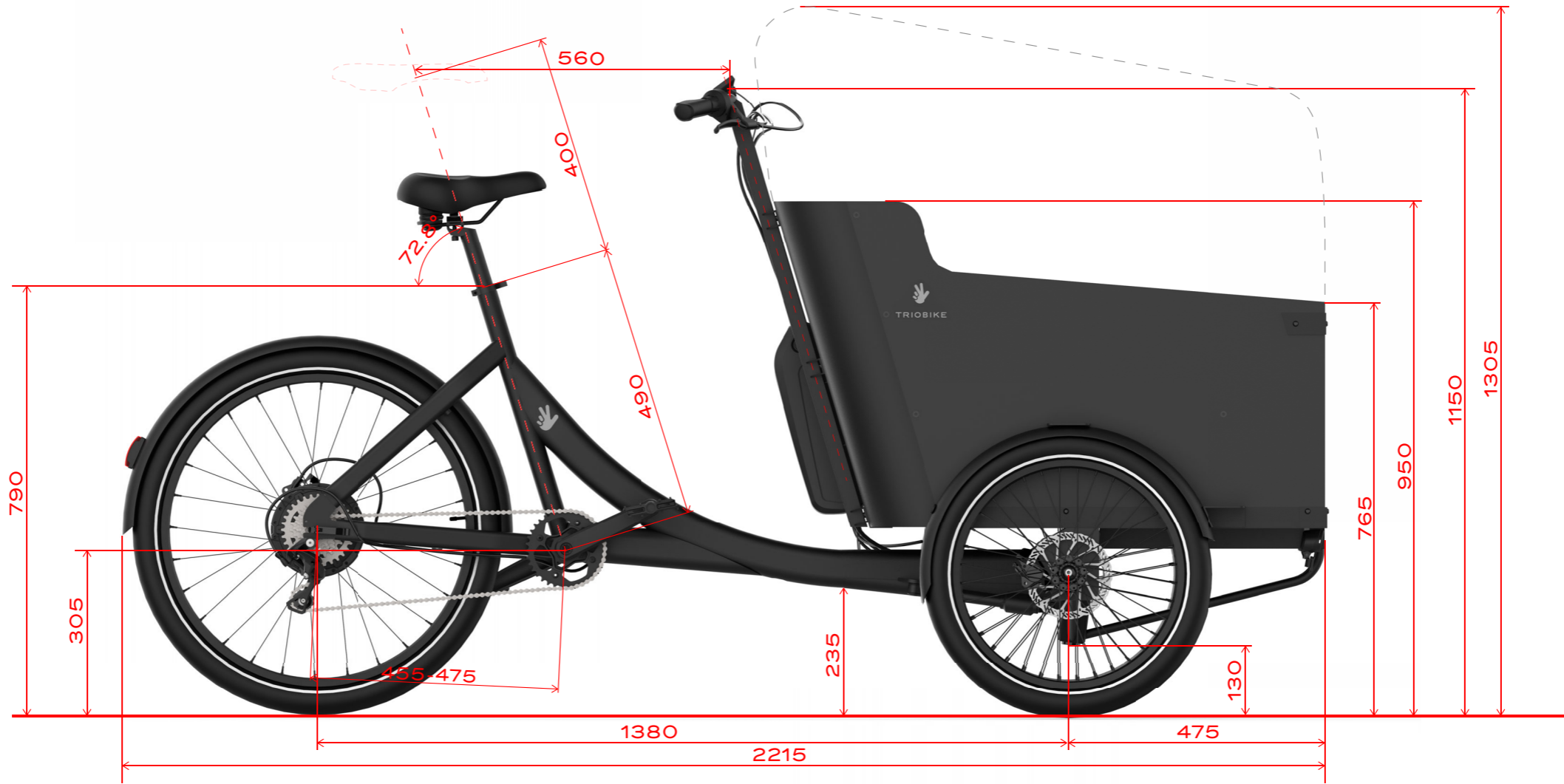

dimensions in mm

TRIOSBIKE Hafnia  
Date: 06-03-2024  
Copyright© TRIOSBIKE A/S 2024



**TRIOBIKE**