



TRIOBIKE



HAFNIA

SEAT ASSEMBLY INSTRUCTIONS

ENGLISH V 1.0



SEAT KIT PARTS

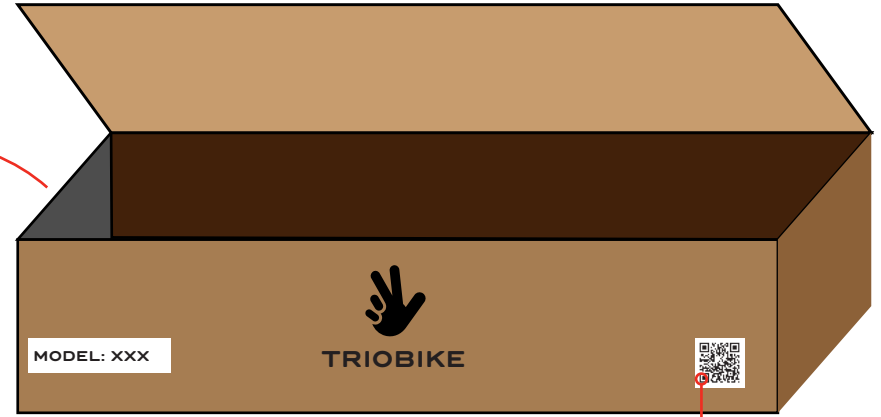
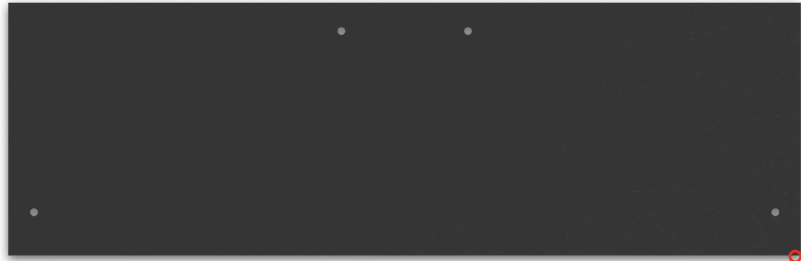

MODEL: XXX

TRIOBIKE



QR code - scan to download the manual

Front seat



3x L shaped brackets:

- 1x front (big)
- 2x side (small)



8x M6 nuts



8x DIN 7991 M6x25 bolts



8x M6 washers



2x 3-points seat belts



6x M6 nuts



8x M6 washers



4x M6 washers



4x DIN 7991 M6x35 bolts



2x DIN 7991 M6x25 bolts



NEEDED TOOLS



1- Hex key, sizes: 4 mm



2- Wrench, sizes: 10 mm



ASSEMBLING THE SEAT

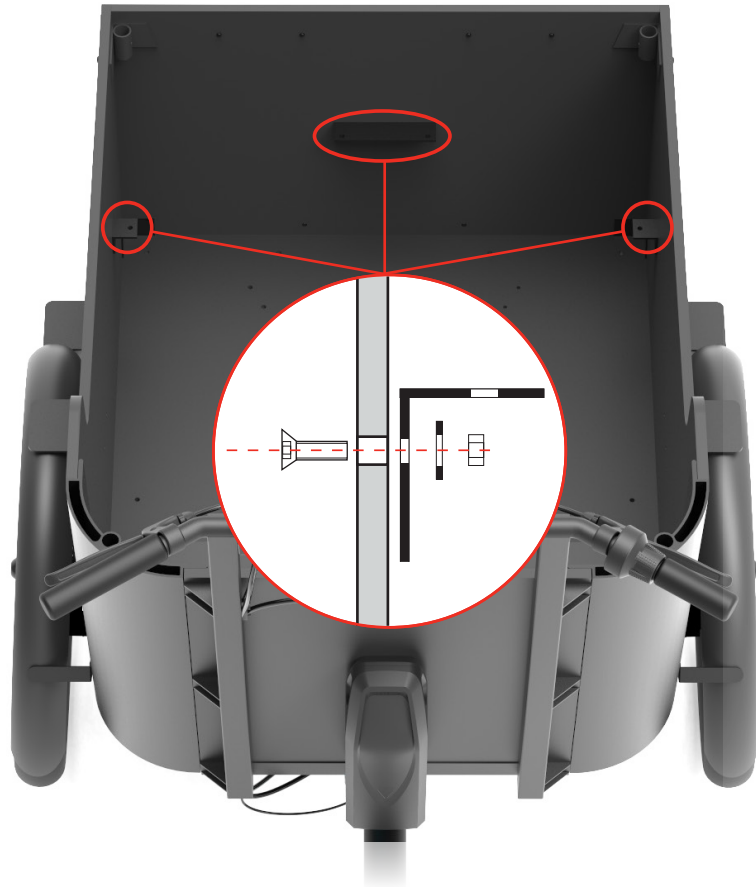

1- Mount the brackets on the box, using 1x M6x25 bolt for each side bracket, and 2x M6x25 bolt for the front one. Put bolts, washers and nuts according to the picture above. **USE TORQUE OF 5 Nm MAX.**

6

ASSEMBLING THE SEAT

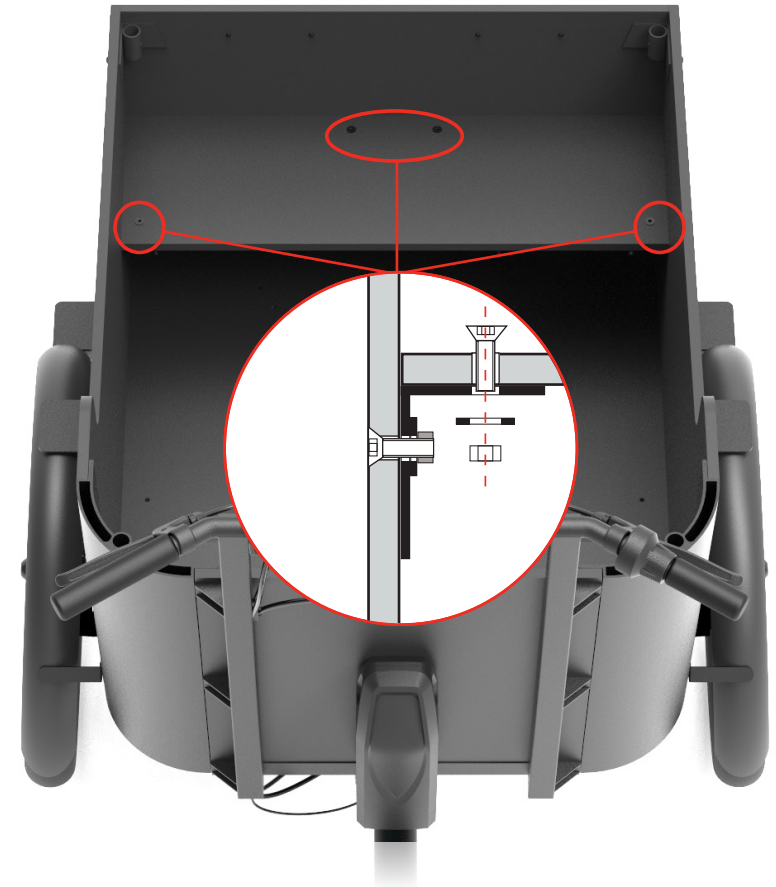

2- Place the front seat on the brackets, aligning the holes. Mount the seat on the brackets using 1x M6x25 bolt for each side bracket, and 2x M6x25 bolt for the front one. Put bolts, washers and nuts according to the picture. **USE A TORQUE OF 5 Nm MAX.**

7

ASSEMBLING THE SEAT

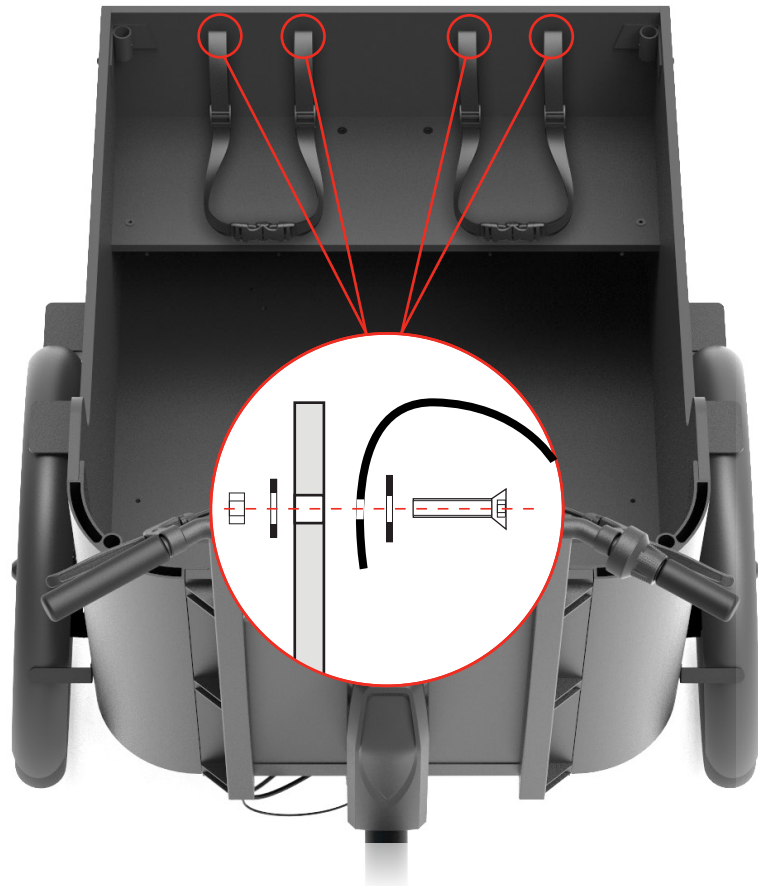

3- Connect seat belt shoulder holders to the wall on the box with 2xM6x35 bolt each in the specific holes. Put bolts, washers and nuts according to the picture.

USE A TORQUE OF 5 Nm MAX.

8

ASSEMBLING THE SEAT

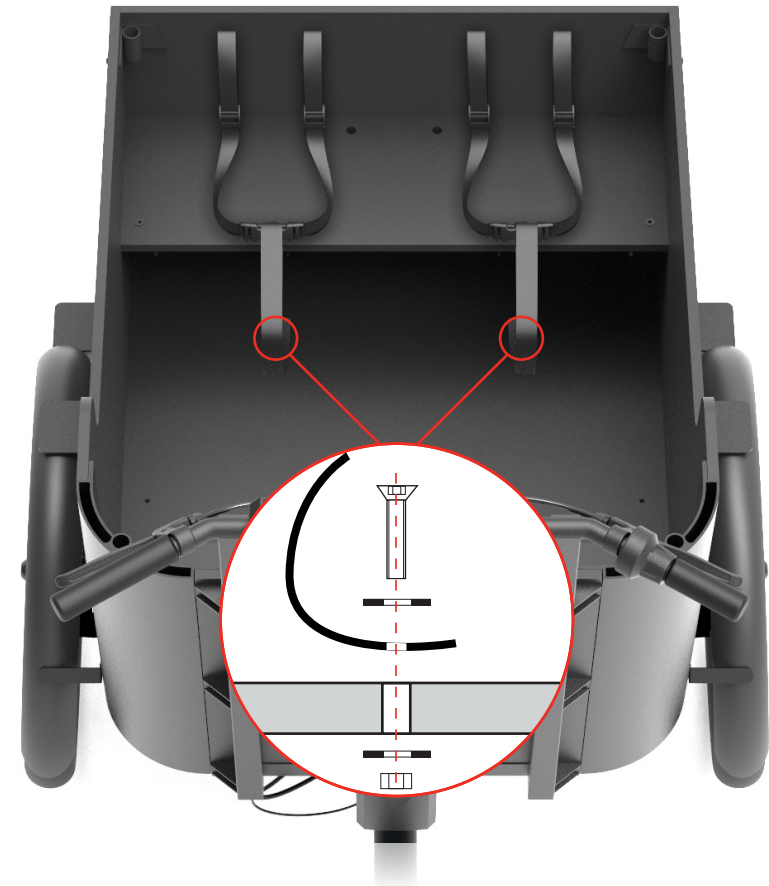

4- Connect seat belt bottom parts to the box floor, using 1xM6x25 bolt each in the specific threaded holes. Put bolts, washers and nuts according to the picture. **USE A TORQUE**

OF 5 Nm MAX.

9



TRIOBIKE

TRIOBIKE A/S

Vesterbrogade 149, 1620 Copenhagen V - Denmark

phone: +45 3670 0070

info@triobike.dk | www.triobike.com